

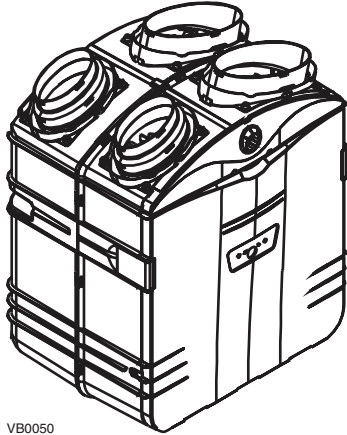

MODEL: HEPA 3100*

Part No. HEPA3100

180 cfm (including 70 cfm of air exchange)
to 270 cfm (including 105 cfm of air exchange)



VB0050

AIR EXCHANGER WITH HEAT RECOVERY AND HEPA FILTRATION**

This whole-house air exchanger is much more than a conventional heat recovery ventilator. In fact, more than preheating air from outside before circulating it throughout the home, the HEPA 3100* is equipped with an HEPA** filter with antimicrobial protection, which traps airborne allergens such as pollen, dust, mold, bacteria, etc.

- Simple and easy installation to furnace ducting or stand alone option (installation kit no. 13932 sold separately)
- Only one outdoor connection
- Cabinet integrated handles
- A total of 270 cfm of filtered air (containing up to 105 cfm of fresh/filtered air coming from outside)
- For houses up to 3,000 sq. ft.***
- 40415 Low voltage wall control with LCD screen included

With its top quality filtration and its heat recovery, this air exchanger will provide your home fresh healthy air and reduce ventilation costs. The HEPA 3100 unit is the optimum solution for you and your family who deserves to live in excellent Indoor Air Quality.

** HEPA: High Efficiency Particulate Air filter.

*** For new constructions, please refer to your local building code.

Available at:

WHOLE-HOUSE AIR EXCHANGER

Control

- The 40415 wall control (included) offers 4 operation modes: Maximum, Minimum, Automatic and Recirculation.
- Its backlight LCD screen with animated icons display permanently the exterior temperature and allows to see in a wink the unit operating mode.
- Its user-friendly programming allows to customize the Automatic mode settings as well as the display (C or F degree and backlight duration).

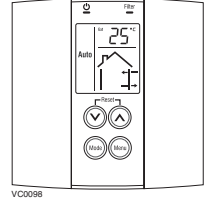

Air exchange and HEPA filtration

1. Stale air from the house is drawn to the unit, and transfers its heat to the fresh incoming air.
2. A portion of the stale air is exhausted to the outside.
3. Fresh air from outside is blended with interior air. Then, the airflow goes through the prefilter (catching the bigger particles) and the antimicrobial HEPA filter, which catches up to 99.97% of 0.3 micron and larger size particles.
4. Fresh filtered air is distributed throughout the house.

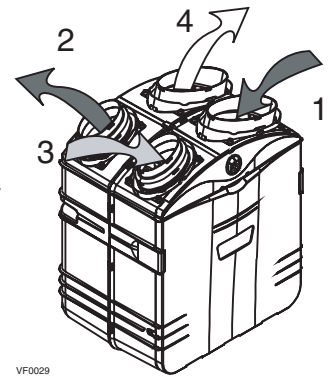

VF0029

Airborne particles trapped

- Pollen
- Fungus spores
- Tobacco smoke
- Bacteria
- Dust mite debris
- Pet danders
- Mold spores
- Dust, etc.

Maintenance

Furthermore to its easy installation, this unit is maintenance troublefree.

The prefilter should be replaced every 6 months and the complete HEPA filter cartridge should be replaced once a year.

No tools are required to perform the maintenance. Also, the motor is factory lubricated; there is no need to oil the motor.

Requirements and Standards

- Complies with CSA C22.2 No. 113-M1984
- Complies with UL 1812

Warranty

In Canada, the HEPA 3100* unit is fully protected by a 2-year warranty on all parts and labor in workshop, except for core filters, filter and prefilter.

In United States, the HEPA 3100* unit is fully protected by a 2-year warranty on all parts only, except for core filters, filter and prefilter.

* Patent pending

Dimensions and Clearances: HEPA 3100*

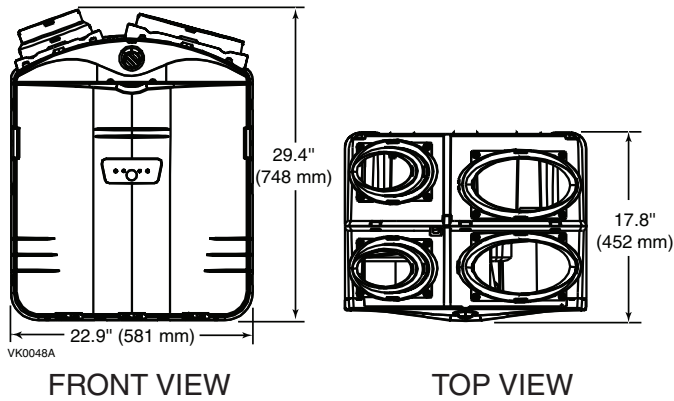

Ventilation Performances

EXTERNAL STATIC PRESSURE	NET VENTILATION AIRFLOW	GROSS AIR FLOW						POWER	
		SUPPLY		EXHAUST		FILTERED			
Pa	in.w.g.	l/s	cfm	l/s	cfm	l/s	cfm	Watts	
50	0,2	52	110	58	124	57	121	277	237
100	0,4	49	103	55	116	51	108	252	229



Installation

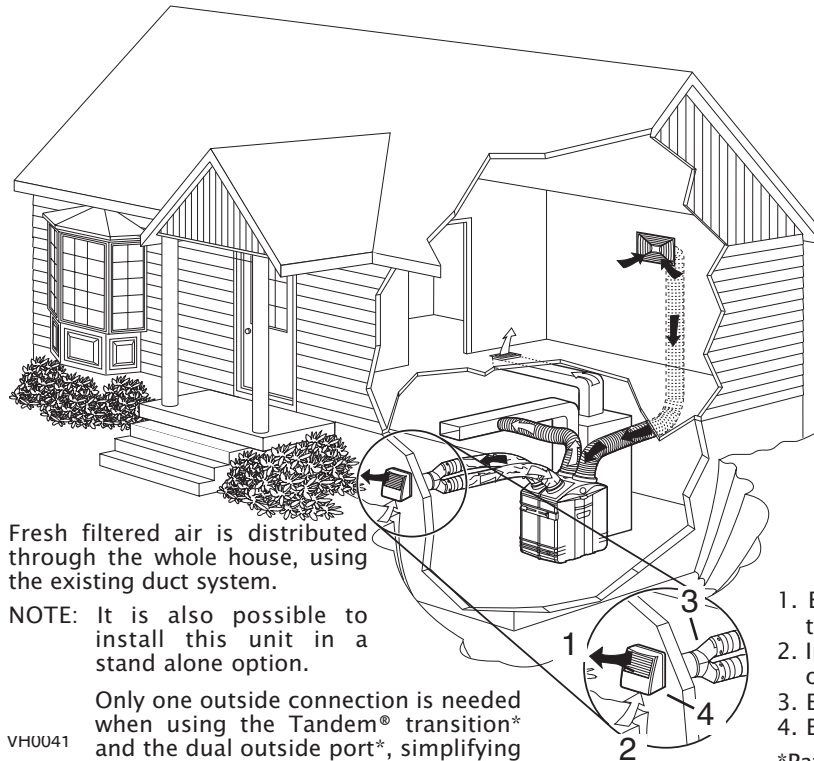

Fresh filtered air is distributed through the whole house, using the existing duct system.

NOTE: It is also possible to install this unit in a stand alone option.

Only one outside connection is needed when using the Tandem® transition* and the dual outside port*, simplifying the installation.

VH0041

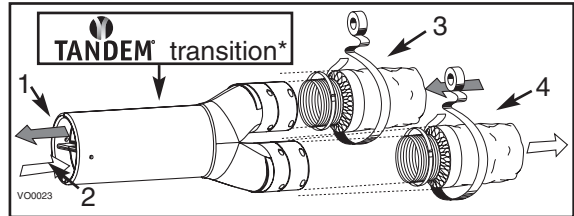

Our exclusive Tandem® transition* (included in the installation kit No.13932) never mixes stale inside air (1) (coming from its unit duct (3)) and fresh air from outside (2) (going through its unit duct (4)).

Both transition and unit ports can be fitted with 5" and 6" diameter insulated flexible ducts.

*Patent pending.

1. Exhaust stale indoor air, at very high speed, on the top of the dual outside port*.
2. Intake of fresh outdoor air, by the bottom of the dual outside port*.
3. Exclusive Tandem® transition*.
4. Exclusive dual outside port*.

*Patent pending.

Specifications and ratings

- Model: HEPA 3100
- Part number No. HEPA3100
- Total assembled weight : 40 lb (18 kg)
- Mounting: Suspension by chains and springs
- Cabinet: Rugged plastic
- Motor and blower: 270 cfm, 3,200 rpm

- Oval ports
 - for non insulated ducts to inside: fits 8" round ducts
 - for insulated ducts to outside: fits 5" or 6" round ducts
- Filtration: One pre-filter plus one HEPA filter with antimicrobial protection

- Wall control operating modes: Maximum, Minimum, Automatic and Recirculation
- Unit Electrical Characteristics:
 - Voltage: 120 volts AC
 - Power: 232 Watts
 - Current: 2 Amps
 - Frequency: 60 Hz

NOTE: All specifications are subjected to change without notice.

Submitted by:		Date:	Project:
Qty:	Model No.:	Remarks:	Location:
			Architect:
			Engineer:
			Contractor:



Residential Product Group, 550 Lemire Blvd., Drummondville, QC, Canada J2C 7W9 - Tel.: 1-800-567-3855 Fax: 1-800-567-1715