



Venmar PRO250
Produit n° PRO250

67 to 130 CFM (0.4 in. w.g.)



VB0118

DISCOVER THE NEW ECO-EFFICIENT VENMAR AIR EXCHANGER PRO250, AVAILABLE EXCLUSIVELY TO CONTRACTORS

When installed by a professional, the Venmar PRO250 air exchanger meets the strictest requirements of government eco-efficient programs in North America and complies with the latest construction industry standards for new homes.

Of all air exchangers available on the retail market, the PRO225 air exchanger delivers the best energy performance in terms of ventilation and heat recovery.

It has been designed to meet building code and Novoclimat™** program requirements market.

- Faster and easier installation of insulated flexible ducts with practical straps (exclusive to Venmar)
- Integrated balancing dampers (exclusive to Venmar)
- Easy to access electronic module
- Homeshield™ defrosting system
- Heat recovery core offers greater comfort
- High-pressure blowers
- Integrated draining system
- ENERGY STAR® qualified

*Novoclimat is a program from the *Agence de l'efficacité énergétique du Québec*.

REPAIRS AND MAINTENANCE

The PRO250 HRV low power consumption PSC motors are permanently lubricated. The electronic circuit board eliminates electromechanical parts, reducing repair time to a minimum.

WARRANTY

The PRO250 unit is protected by a complete 2-year warranty on all parts and labor in workshop only.

The heat recovery core is covered by a limited lifetime warranty, with the original proof of purchase.

Available at:

HEAT RECOVERY VENTILATOR

Controls

- This unit is very simple to operate. Once it is installed, press on its push button, located under the unit, to activate it. Press once for low speed, once again for high speed, and once more to stop it.
- The Breeze wall control is included with the PRO250. It offers 3 modes of operation:
 - Recirculation: the unit recirculates ambient air without drawing in outdoor air.
 - Minimum: minimum air exchange.
 - Automatic: turns on automatically for 20 minutes in exchange mode and turns off for 40 minutes.
- The optional 20-min. lighted push-button bathroom control, no. 12030, can be added.

Homeshield™ Defrosting System

The PRO250 HRV uses a unique defrosting method. No negative pressure is created by air exhausted to the outdoors, as the air is recirculated into the house, thus avoiding any backdraft from the chimney. Moreover, this defrost method by air circulation ensures that no shortage of air is created for the combustion units.

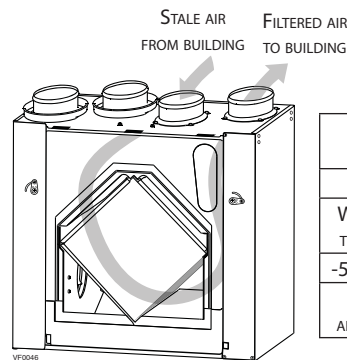

OUTDOOR TEMPERATURE		DEFROST CYCLE DEFROSTING MIN./ OPERATING MIN.
°C	°F	
WARMER THAN -5	WARMER THAN 23	PAS DE DÉGIVRAGE
-5 TO -27	23 TO -17	7/25
-27 AND LESS	-17 AND LESS	10/22

Heat Recovery Core

Dimensions: 10" x 10" x 14.25" (25.4 cm x 25.4 cm x 36.2 cm)

Exchange surface: 100 ft² (9.3 m²)

Weight: 7.36 lb (3.3 kg)

Material: Polypropylene

Type: Cross flow

Warranty: Limited lifetime

Requirements and Standards

- Complies with the UL 1812 requirements regulating the installation of Heat Recovery Ventilators.
- Complies with the CSA C22.2 no. 113 Standard applicable to ventilators
- Complies with CSA C444 requirements regulating the installation of Heat Recovery Ventilators
- Technical data was obtained from published results of tests relating to CSA C439 Standards
- HVI certified and ENERGY STAR® qualified

DIMENSIONS AND SERVICE CLEARANCES: PRO250

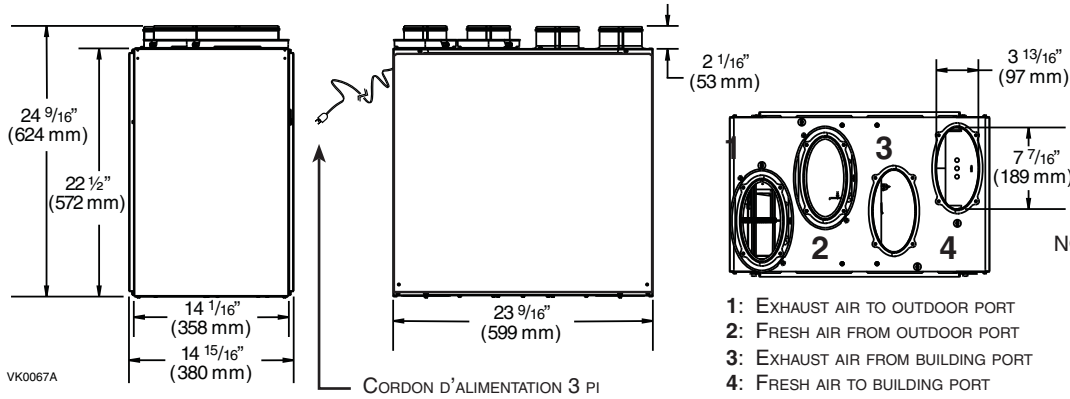

NOTE: ALL UNITS PORTS WERE CREATED TO BE CONNECTED TO DUCTS HAVING A MINIMUM OF 6" DIAMETER, BUT IF NEED BE, THEY CAN BE CONNECTED TO BIGGER SIZED DUCTS BY USING AN APPROPRIATE TRANSITION (E.G.: 6" DIAMETER TO 7" DIAMETER TRANSITION).

- 1: EXHAUST AIR TO OUTDOOR PORT
- 2: FRESH AIR FROM OUTDOOR PORT
- 3: EXHAUST AIR FROM BUILDING PORT
- 4: FRESH AIR TO BUILDING PORT

VENTILATION PERFORMANCE

EXTERNAL STATIC PRESSURE		NET SUPPLY AIR FLOW		GROSS AIR FLOW			
Pa	in. w.g.	l/s	CFM	SUPPLY		EXHAUST	
Pa	in. w.g.	l/s	CFM	l/s	CFM	l/s	CFM
25	0.1	76	161	77	163	77	162
50	0.2	72	152	72	153	72	152
75	0.3	67	142	68	143	67	141
100	0.4	62	131	63	132	62	131
125	0.5	56	119	56	119	58	123
150	0.6	52	110	53	111	53	111
175	0.7	46	98	47	99	48	100
200	0.8	40	84	40	84	41	87
225	0.9	34	72	34	73	36	77
250	1.0	28	59	28	59	29	62

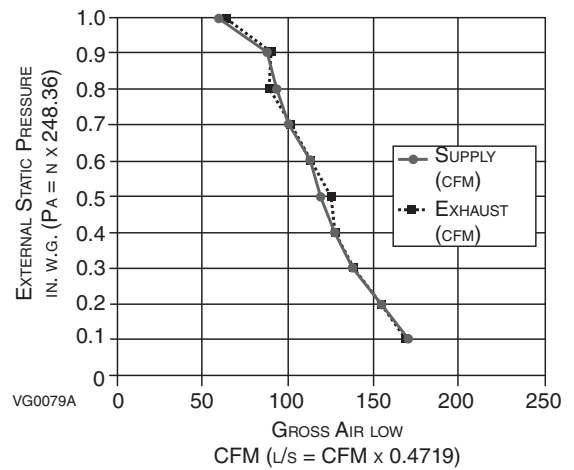

ENERGY PERFORMANCE

SUPPLY TEMPERATURE		NET AIR FLOW		POWER CONSUMED	SENSIBLE RECOVERY EFFICIENCY	APPARENT SENSIBLE EFFECTIVENESS	LATENT/RECOVERY MOISTURE TRANSFER
°C	°F	l/s	CFM	WATTS			
HEATING							
0	32	32	67	56	70	78	0.00
0	32	40	86	64	68	75	0.01
0	32	56	120	86	64	70	0.01
-25	-13	30	63	79	61	83	0.01

NOTE: All specifications are subject to change without notice.

SPECIFICATIONS AND RATINGS

- Model: PRO250
- Part number: PRO250
- Total assembled weight (including polypropylene core): 52.4 lb (23.8 kg)
- Oval shaped ports; fit 6" round ducts
- Drains: 1/2" (1.2 cm) fittings with 10 ft (3 m) PVC drain
- Core filters: 2 washable MERV 6 9.2" x 14.25" x 0.38" (23.4 cm x 36.2 cm x 1 cm)
- Mounting: Suspension by chains and springs
- 2 PSC Blower Motors (supply and exhaust)
 - Protection type: thermally protected
 - Insulation class: F
- Speed control on unit:
 - Low and High speeds
 - Other modes available with Breeze main wall control
- Insulation: Expanded polystyrene
- Housing: prepainted steel
- Heat recovery core:
 - Heat exchagne surface area: 100 ft² (9.3 m²)
 - Type: Cross flow
 - Material: Polypropylene
- Unit electrical characteristics:

Volts	Frequency	Ampere	Watts
120	60 Hz	0.96	105

Project:	REMARKS
Location:	
Part no.: PRO250	
Quantity:	
Submitted by: _____ Date: _____	



Residential Product Group, 550 Lemire Blvd., Drummondville, QC, Canada J2C 7W9 - Tel.: 1-800-567-3855 Fax: 1-800-567-1715



www.venmar.ca

PRO250d170330