

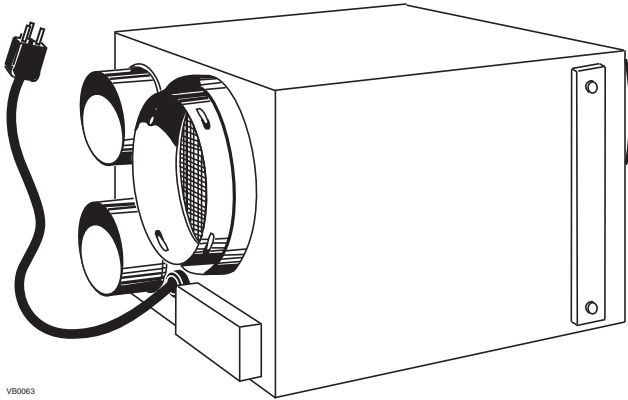

**Model: EA 1500**

**Part no. EA1500**

160 cfm (including 30 cfm of air exchange)  
to 185 cfm (including 55 cfm of air exchange)



VB0063

**AN AFFORDABLE SOLUTION FOR HOUSES WITH EXCESS HUMIDITY PROBLEM.**

The Venmar EA 1500 is the cost-effective air exchange unit. It is the minimal requirement for improved Indoor Air Quality, continuous air exchange and excess humidity control.

- Intake and exhaust ports for indoor air have a 6" (15 cm) diameter, to facilitate the installation in a new house
- 5" (12 cm) diameter adapters (included) for intake and exhaust ports to outdoor air if needed for a retrofit application
- Plug-in module, simplifying the installation
- Installation kit including our exclusive Tandem® transition\* and the dual outside port\*, for a one outdoor connection (Kit part no. 15273)
- C34 low voltage control (included), allowing air recirculation
- User friendly and easy maintenance
- Quick installation for houses with bathroom fan and up to 2,000 sq. ft.\*\*
- Mechanical air filtration by a washable mesh filter
- Can be installed in the attic

\*Patented.

\*\*For new constructions, please refer to your local building code.

The EA 1500 air exchanger controls excess humidity in the house, thus reducing risk of condensation in windows.

The installation for this ventilation system is quick and easy for all types of houses.

Available at:

**WHOLE-HOUSE AIR EXCHANGER**

**Control**

- The EA 1500 air exchanger is ready to receive C34 wall control (included with the unit)
- This control offers 3 operating modes: Minimum, Maximum and Recirculation
- The Fresh air indicator lights up when the unit is on Minimum or Maximum mode
- Also, this control is equipped with a Maintenance indicator, telling you when it is time to perform the filter maintenance



VC0114

**Air flow during air exchange**

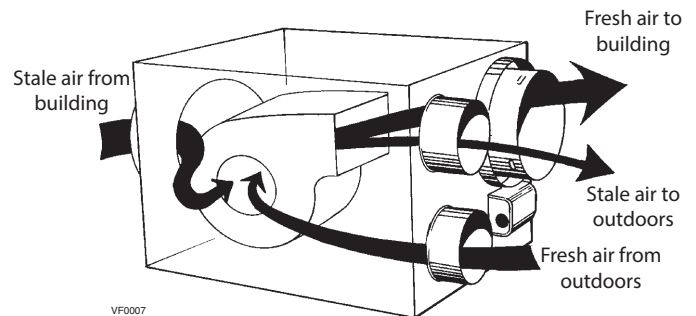

VF0007

**Inside damper open**

**Warranty**

In Canada, the EA 1500 is fully protected by a 2-year warranty on all parts and labor in workshop only.

In the United States, the EA 1500 is fully protected by a 2-year warranty on all parts only.

**Requirement and Standard**

- Complies with the CSA C22.2 no. 113 Standard applicable to ventilators.
- Complies with UL 507 Standard.

## Dimensions and Clearances: Venmar EA 1500

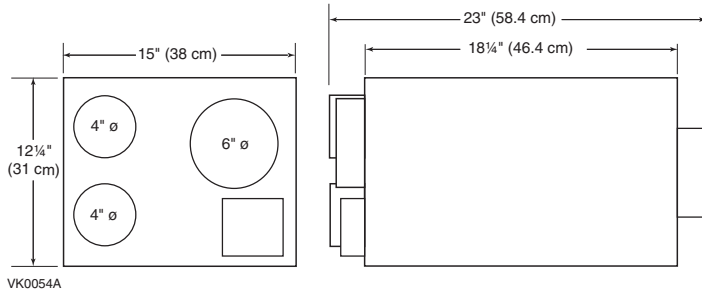

VK0054A

## Attic Installation\*

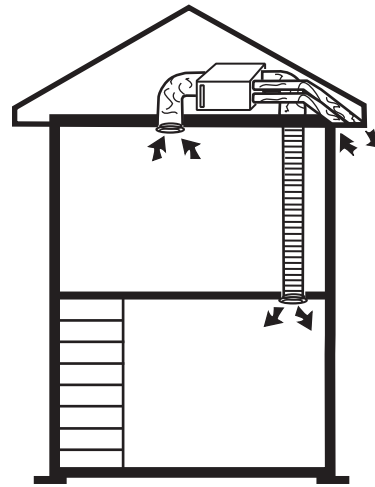

\* When the EA 1500 is installed in the attic, the unit must always be in operation during cold season. Use the installation kit no. EA20130.

VH0004

## Basement Installation

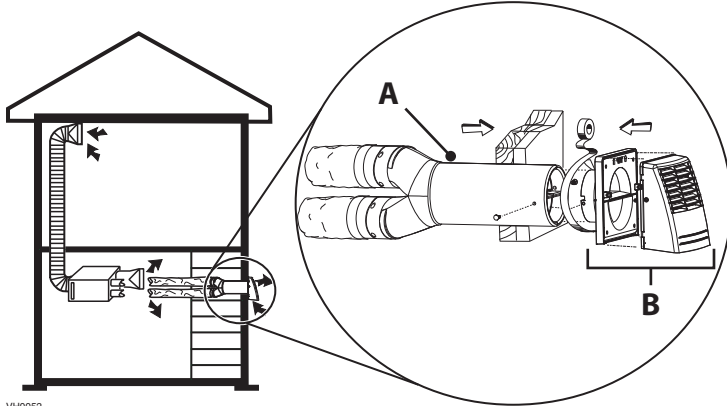

VH0052

Only one outside connection is needed when using the Tandem® transition (A) and the dual outside port (B), simplifying the installation. (Both A and B are included in installation kit no. 15273).

## Ventilation performances

EXTERNAL STATIC PRESSURE		NET VENTILATION AIR FLOW		GROSS AIR FLOW RECIRCULATION		POWER
PA	IN. W.G.	L/S	CFM	L/S	CFM	WATTS
50	0.2	26	56	104	220	139
100	0.4	17	35	88	187	135

## SPECIFICATIONS

- Model: EA 1500
- Part number: EA1500
- Total assembled weight: 40 lb. (18 kg)
- Supply air duct connections:
  - stale: 4" or 5" (10 cm or 12 cm)
  - fresh: 6" (15.25 cm)
- Exhaust air duct connections:
  - stale: 6 (15.25 cm)
  - fresh: 4» or 5» (10 cm or 12 cm)
- Filter: 1 mesh filter
- Housing: pre-painted steel
- Dimensions: 23" x 12 1/4" x 15" (58.4 cm x 31 cm x 38 cm)
- Mounting: Suspension by chains and springs
- Control modes: Minimum, Maximum and Recirculation
- Unit electrical characteristics:
 

Volts	Frequency	Amps	Watts
120	60 Hz	1.2	140

Project:	REMARKS
Location:	
Part number: EA1500	
Quantity:	
Submitted by:	Date: