

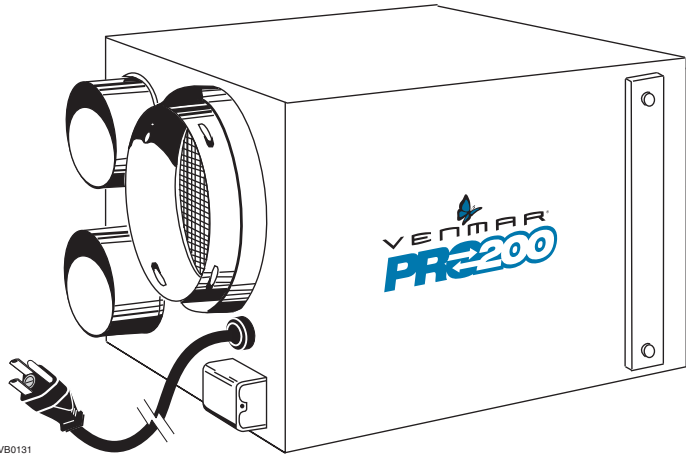

VENMAR PRO 200



VB0131

AIR CIRCULATION AT LOW PRICE; UNIT EXCLUSIVELY AVAILABLE TO CONTRACTORS

Recognized for its unsurpassed quality and superior craftsmanship, the PRO 200 offers the essential features to ensure a good ventilation and control the humidity level, thus improving Indoor Air Quality of your house.

- Plug-in module, simplifying the installation
- Intake and exhaust ports for indoor air have a 6" (15 cm) diameter, to facilitate the installation
- User friendly and easy maintenance
- Quick installation for all types of houses
- Mechanical air filtration by a washable filter

By controlling excess humidity in the house and by reducing the risk of condensation in windows, the PRO 200 increases comfort by distributing heat and humidity throughout the house. The installation for this ventilation system is quick and easy for all types of houses.

Available at:

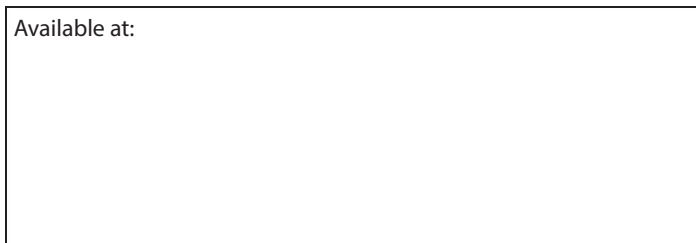

AIR EXCHANGER

Control

- The PRO 200 air exchanger is ready to receive control no. 11417 (included in the box). This wall control works with a dehumidistat that allows you to select the desired level of humidity according to your needs and offers two operating modes.
- **Intermittent exchange:** If the selector is set above the click, the unit will stop. If the selector is set below the click, the unit will exchange with the outside on high speed until the desired humidity level has been reached.
- **Continuous circulation:** If the selector is set above the click, the unit produces continuous air circulation throughout the house. If the selector is set below the click, the unit will exchange with the outside on high speed until the desired humidity level has been reached.

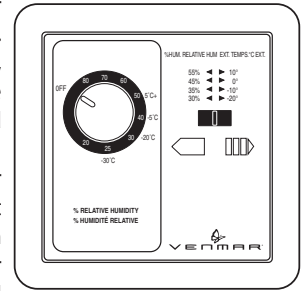

VC0025

Control no. 11417

Air flow during exchange

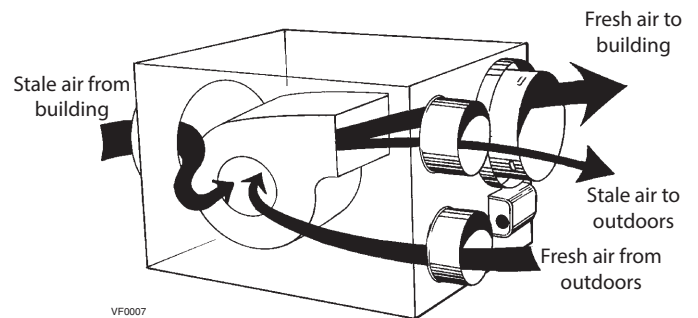

VF0007

Inside damper open

Warranty

The PRO 200 is fully protected by a 2-year warranty on all parts and labor in workshop only.

Home servicing is offered when the unit is installed by a Venmar Recommended Installer.

Requirement and Standard

- Complies with the CSA C22.2 no. 113 Standard applicable to ventilators.

Dimensions and Clearances: Venmar PRO 200

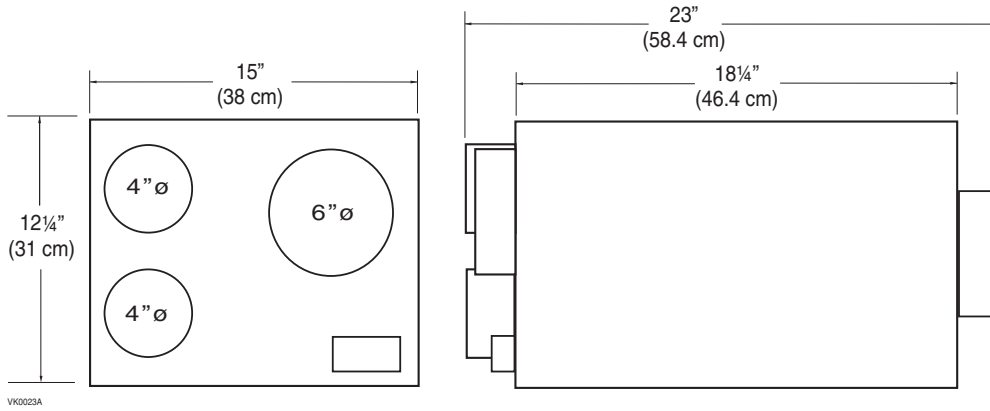

Basement Installation

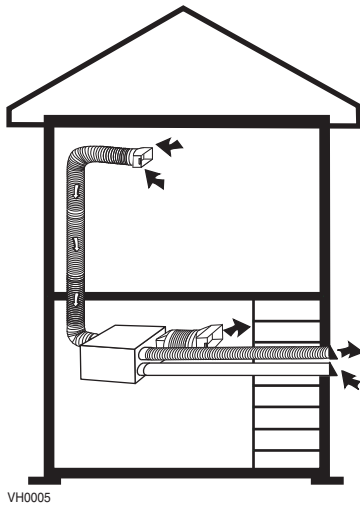

Attic Installation*

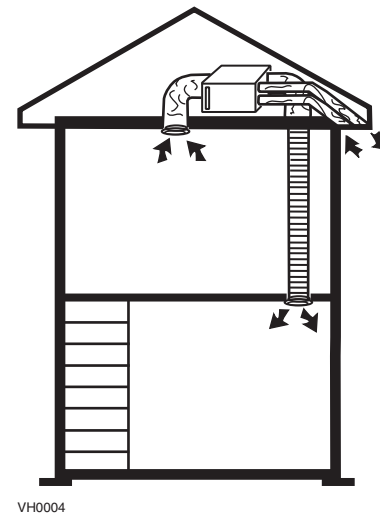

* If installed in the attic, the unit must be in continuous mode during cold season.

Specifications and Rating

- Model: PRO 200
- Total Assembled Weight: 40 lb. (18 kg)
- Supply Air Duct Connections:
 - Stale Air: 4" (10 cm)
 - Fresh Air: 6" (15.25 cm)
- Exhaust Air Duct Connections:
 - Stale Air: 6" (15.25 cm)
 - Fresh Air: 4" (10 cm)
- Filter: 1 mechanical filter
- Cabinet: pre-painted steel
- Dimensions: 23" x 12 1/4" x 15" (58.4 cm x 31 cm x 38 cm)
- Fresh Air Intake Air Flow: 30 to 50 CFM (15 to 25 l/s)
- Stale Air Exhaust Air Flow: 80 CFM (40 l/s)
- Intake and Exhaust Interior Airflow: 160 CFM (75 l/s)
- Control with two operating mode: 120 volts
- Wall Control Available Modes: stop, exchange and continuous circulation
- Unit Electrical Characteristics:

| | | |
|---------|-------|---------|
| Voltage | Power | Current |
| 120 V | 200 W | 3 Amps |

| | |
|---------------------------------|---------|
| Project: | REMARKS |
| Location: | |
| Model no.: PRO200 | |
| Quantity: | |
| Submitted by: _____ Date: _____ | |



Residential Products Group, 550 Lemire Blvd., Drummondville, QC, Canada J2C 7W9 - Tel.: 1-800-567-3855 Fax : 1-800-567-1715

www.venmar.ca

90616 (14_12)

